



MH180

MATERIAL HANDLING | MACHINE TENDING | PRESS TENDING

KEY BENEFITS

Small mounting surface and minimum interference radius save valuable floorspace

Optimized robot design with increased speed reduces cycle time

Increased payload, moment and inertia ratings allow the robots to be used in a wide variety of applications

Slim wrist profile for high density spacing and for reaching into confined spaces

SPECIFICATIONS

180 kg payload (MH180)
 2,702 mm horizontal reach
 3,393 mm vertical reach
 ±0.2 mm repeatability
 Floor mounted

CONTROLLERS

DX200
 MLX200
 MLX300*

- Powerful six-axis handling robot features high-rigidity speed reducers and high-speed motion which reduce cycle times.
- The MH180 features increased payload capacity as well as increased speed of each axis over previous models.
- High payload and increased moment and inertia ratings allow the robot to handle larger and heavier payloads.
- Streamlined upper arm design features a slim wrist profile and reduces robot width by over 200 mm. This allows easier reach into confined spaces, improving application flexibility.
- Base design reduces robot interference radius to only 515 mm, the lowest in its class. This allows the robot to be mounted closer to machines and fixtures, making best use of valuable floorspace.
- Improved design removes the counterbalance from robot base. This reduces the mass of the arm, enabling higher acceleration, deceleration and speed.
- The required mounting surface is reduced by nearly 44%, saving valuable floor space and making the robot easier to apply.
- Up to 70% less power consumption during motion and 25% savings during idle periods compared to previous models.
- Cables and air lines are routed through robot base to upper arm to increase cable life, enhance safety and reduce teaching time.
- Cable installation tube in the base of the robot facilitates fieldbus routing to the robot upper arm and/or gripper.
- Pre-wired for servo gripper which allows a wider range of product handling.
- The MH180 has an IP67-rated wrist and an IP54-rated body.

HA 60 65 70 75 80 85 90 95

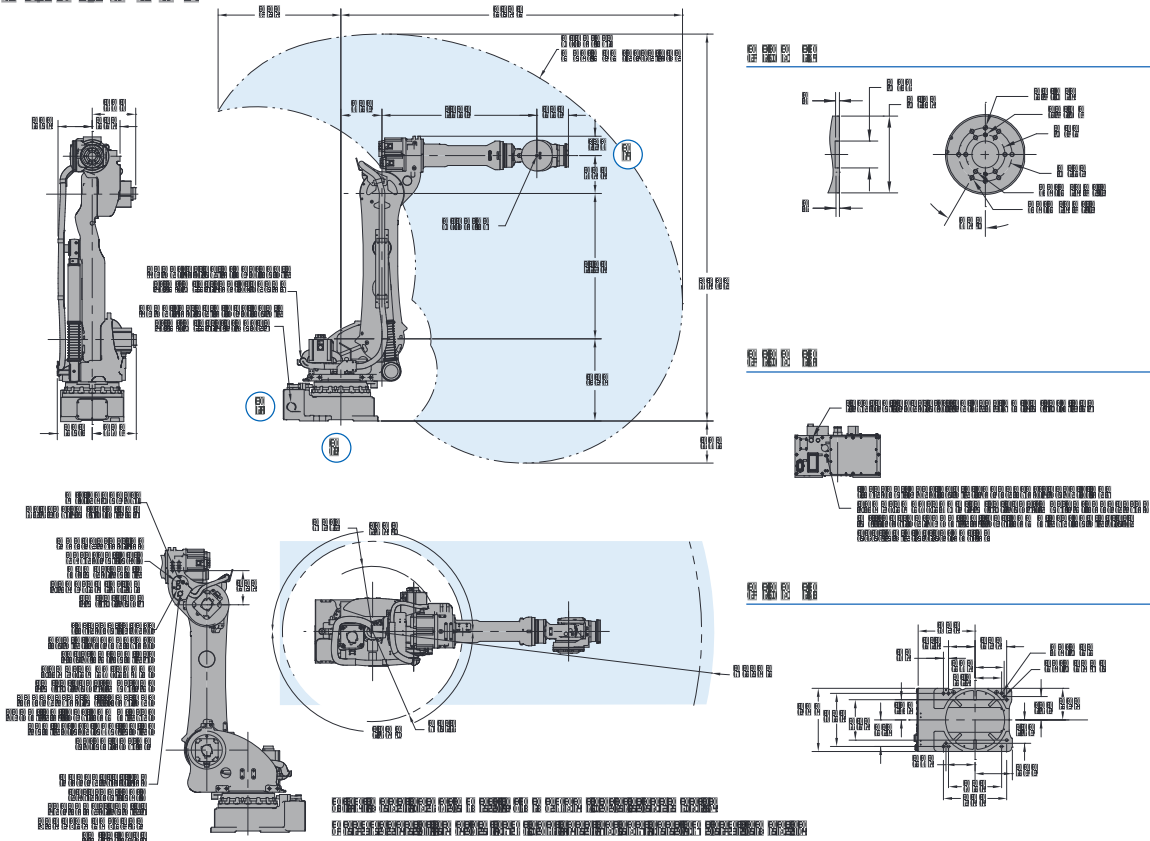

HA 60 65 70 75 80 85 90 95

HA 60	HA 65	HA 70	HA 75	HA 80	HA 85	HA 90	HA 95
...
...
...
...
...
...
...

HA 60 65 70 75 80 85 90 95

HA 60 65 70 75 80 85 90 95

HA 60 65 70 75 80 85 90 95

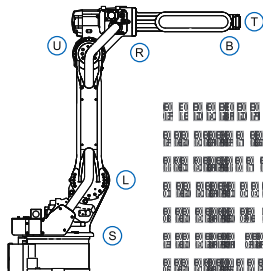

HA 60 65 70 75 80 85 90 95

HA 60 65 70 75 80 85 90 95

HA 60 65 70 75 80 85 90 95

YASKAWA

HA 60 65 70 75 80 85 90 95